

SOT23 PNP SILICON PLANAR SMALL SIGNAL TRANSISTORS

BCX71

ISSUE 3 – MARCH 2005

PARTMARKING DETAIL –

- BCX71G – BG
- BCX71H – BH
- BCX71J – BJ
- BCX71K – BK
- BCX71GR – CG
- BCX71HR – 6P
- BCX71JR – J8
- BCX71KR – CK

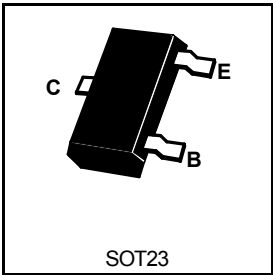

ABSOLUTE MAXIMUM RATINGS.

PARAMETER	SYMBOL	VALUE	UNIT
Collector-Base Voltage	V_{CES}	-45	V
Collector-Emitter Voltage	V_{CEO}	-45	V
Emitter-Base Voltage	V_{EBO}	-5	V
Continuous Collector Current	I_C	-200	mA
Base Current	I_B	-50	mA
Power Dissipation at $T_{amb}=25^{\circ}C$	P_{TOT}	330	mW
Operating and Storage Temperature Range	$T_J:T_{stg}$	-55 to +150	$^{\circ}C$

SWITCHING CIRCUIT

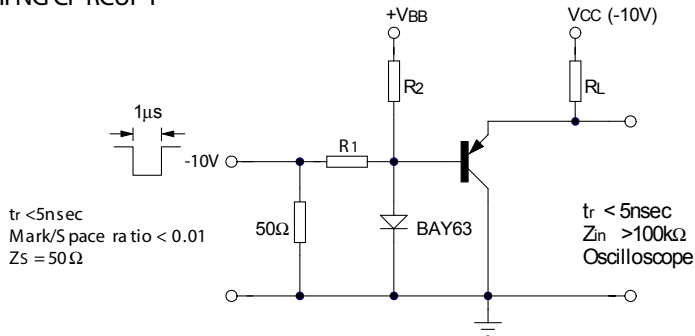

FOUR TERMINAL NETWORK DATA ($I_C=2mA$, $V_{CE}=5V$, $f=1kHz$)

	h_{FE} Group G			h_{FE} Group F			h_{FE} Group J			h_{FE} Group K			
	Min.	Typ.	Max.	Min.	Typ.	Max.	Min.	Typ.	Max.	Min.	Typ.	Max.	
h_{11e}	1.6	2.7	4.5	2.5	3.6	6.0	3.2	4.5	8.5	4.5	7.5	12	K
h_{12e}		1.5			2			2			3		10^{-4}
h_{21e}		200			260			330			520		
h_{22e}		18	30		24	50		30	60		50	100	μs

Spice parameter data is available upon request for this device

BCX71

ELECTRICAL CHARACTERISTICS (at $T_{amb} = 25^{\circ}\text{C}$ unless otherwise stated).

PARAMETER		SYMBOL	MIN.	TYP.	MAX.	UNIT	CONDITIONS.
Collector-Emitter Breakdown Voltage		$V_{(BR)CEO}$	-45			V	$I_{CEO} = -2\text{mA}$
Emitter-Base Breakdown Voltage		$V_{(BR)EBO}$	-5			V	$I_{EBO} = -1\mu\text{A}$
Collector-Emitter Cut-off Current		I_{CES}			-20 -20	nA μA	$V_{CE} = -45\text{V}$ $V_{CE} = -45\text{V}, T_{amb} = 150^{\circ}\text{C}$
Emitter-Base Cut-Off Current		I_{EBO}			-20	nA	$V_{EBO} = -4\text{V}$
Collector-Emitter Saturation Voltage		$V_{CE(sat)}$		-0.12 -0.25	-0.25 -0.55	V V	$I_C = -10\text{mA}, I_B = -0.25\text{mA}$ $I_C = -50\text{mA}, I_B = -1.25\text{mA}$
Base-Emitter Saturation Voltage		$V_{BE(sat)}$	-0.60 -0.68	-0.70 -0.80	-0.85 -1.05	V V	$I_C = -10\text{mA}, I_B = -0.25\text{mA}$ $I_C = -50\text{mA}, I_B = -1.25\text{mA}$
Base - Emitter Voltage		V_{BE}	-0.6	-0.55 -0.65 -0.72	-0.75	V V V	$I_C = -10\mu\text{A}, V_{CE} = -5\text{V}$ $I_C = -2\text{mA}, V_{CE} = -5\text{V}$ $I_C = -50\text{mA}, V_{CE} = -1\text{V}$
Static Forward Current Transfer Ratio	BCX71G	h_{FE}	120 60	140 170	220		$I_C = -10\mu\text{A}, V_{CE} = -5\text{V}$ $I_C = -2\text{mA}, V_{CE} = -5\text{V}$ $I_C = -50\text{mA}, V_{CE} = -1\text{V}$
	BCX71H		30 180 80	200 250	310		$I_C = -10\mu\text{A}, V_{CE} = -5\text{V}$ $I_C = -2\text{mA}, V_{CE} = -5\text{V}$ $I_C = -50\text{mA}, V_{CE} = -1\text{V}$
	BCX71J		40 250 100	270 350	460		$I_C = -10\mu\text{A}, V_{CE} = -5\text{V}$ $I_C = -2\text{mA}, V_{CE} = -5\text{V}$ $I_C = -50\text{mA}, V_{CE} = -1\text{V}$
	BCX71K		100 380 110	340 500	630		$I_C = -10\mu\text{A}, V_{CE} = -5\text{V}$ $I_C = -2\text{mA}, V_{CE} = -5\text{V}$ $I_C = -50\text{mA}, V_{CE} = -1\text{V}$
Transition Frequency		f_T		180		MHz	$I_C = -10\text{mA}, V_{CE} = -5\text{V}$ $f = 100\text{MHz}$
Emitter-Base Capacitance		C_{ebo}		11		pF	$V_{EBO} = -0.5\text{V}, f = 1\text{MHz}$
Collector-Base Capacitance		C_{cbo}			6	pF	$V_{CBO} = -10\text{V}, f = 1\text{MHz}$
Noise Figure		N		2	6	dB	$I_C = -0.2\text{mA}, V_{CE} = -5\text{V}$ $R_G = 2\text{K}\Omega, f = 1\text{KHz}$ $\Delta f = 200\text{Hz}$
Switching times:							
Delay Time		t_d		35		ns	
Rise Time		t_r		50		ns	
Turn-on Time		t_{on}		85	150	ns	
Storage Time		t_s		400		ns	
Fall Time		t_f		80		ns	
Turn-Off Time		t_{off}		480	800	ns	
							$-I_C : I_{B1} : -I_{B2} = 10:1:1\text{mA}$ $R_1 = R_2 = 5\text{K}\Omega$ $V_{BB} = -3.6\text{V}, R_L = 990\Omega$

*Measured under pulsed conditions. Pulse width=300 μs . Duty cycle